



## CHILLER MODEL: GD-14H-2LC-VA2

230 Volt 1 Phase	
FLA	-
MCA	-
MOC	-

230 Volt 3 Phase	
FLA	84
MCA	93
MOC	128

460 Volt 3 Phase	
FLA	43
MCA	47
MOC	65

Dimensions <sup>1</sup>	45"W x 140"L x 102"H
Frame	Powder Coated Steel
Housing	Powder Coated Aluminum
Tank	50 Gallon Stainless Steel
Compressor	7 HP Two-Stage Recip (x2)
Condenser	Air-Cooled Vertical Discharge
Process Pump	3 HP
Flow Rate	12 GPM @ 25 PSI
Connection Size	1" CTS Flange
Heat Exchanger	Stainless Steel Brazed Plate
Controls	Microprocessor w/ Comm.

Electrical Enclosure	NEMA 3R
Refrigerant	R404a

### *Cooling Capacity by Leaving Fluid Temperature<sup>2</sup>*

LFT	Btu/H	kW
-50 °F	30,700	9.0
-40 °F	41,500	12.2
-30 °F	55,900	16.4

<sup>1</sup> Dimensions accurate for package chiller, remote condenser options will vary

<sup>2</sup>All capacities at 90 °F ambient

### *Chiller package consists of the following:*

- Two complete refrigeration circuits
- Air-cooled condenser
- Coolant pump
- Fluid bypass valve
- Freeze stat safety switch
- CTS flange coolant connections
- All insulated copper piping
- Powder coated steel frame
- Powder coated aluminum housing
- Semi-hermetic two-stage reciprocating compressors with subcoolers
- Engineered high efficiency heat exchanger for maximum energy savings
- Heavily insulated stainless steel coolant reservoir
- Microprocessor controller with communication
- ETL (UL508) listed complete control panel with single point electrical connection, breakers, starters & safety switches
- Louvered aluminum access panels for easy service & maintenance
- Factory run tested and fully charged with refrigerant

**2 Year Parts and 1 Year Labor Warranty**

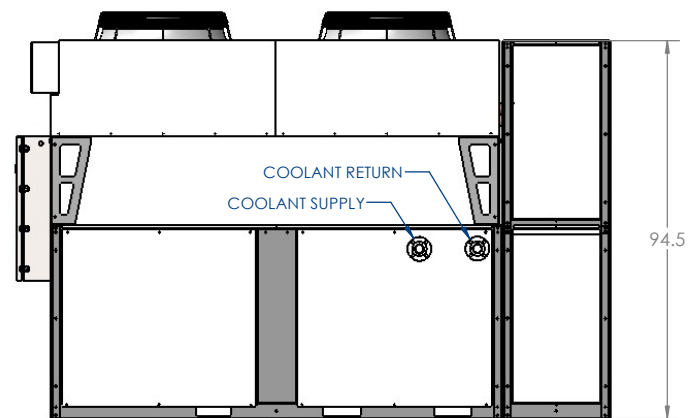
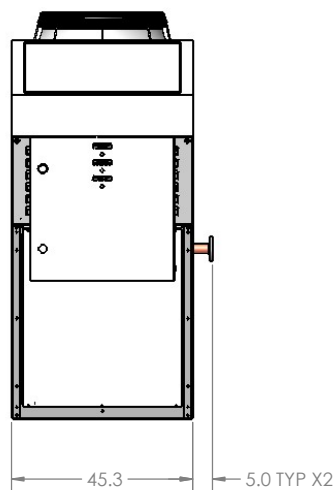
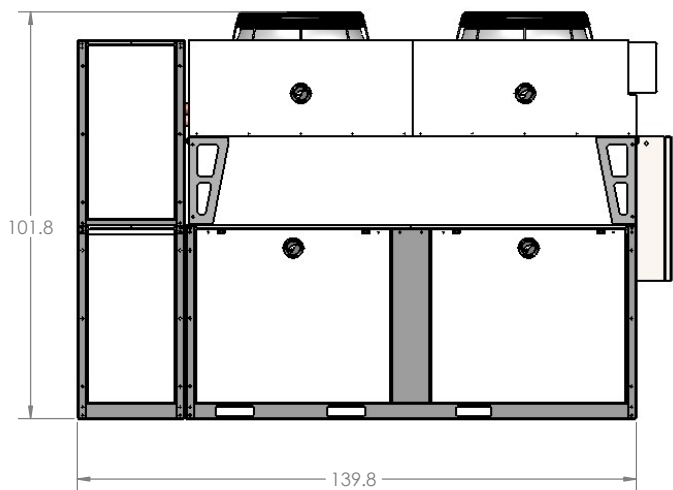
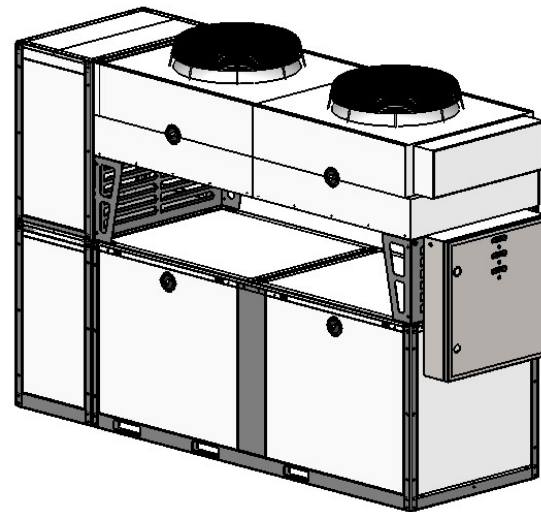
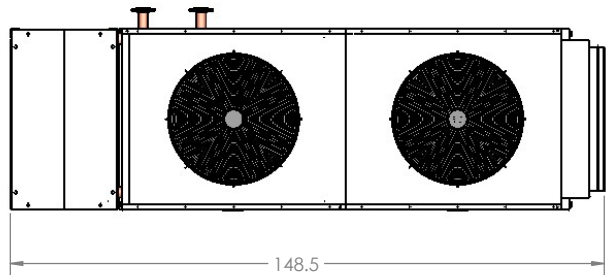

GD-14H-2LC

LOW TEMPERATURE CHILLER



G&D CHILLERS

COMMITTED TO COLD

EST 1993

760 BAILEY HILL RD, EUGENE, OR 97402 - TEL (541) 345-3903 (800) 555-0973